

# BioGill Tower Plus



## Above Ground, Attached Growth Bioreactor For Wastewater Treatment

The BioGill Tower is an attached growth bioreactor for secondary biological wastewater treatment. The smallest bioreactor in the BioGill product range, the Tower is designed to fit tight spaces and is ideal for facilities producing low wastewater volumes or for adding capacity to existing wastewater treatment systems. BioGill bioreactors are simple to install and easy to operate, with minimal maintenance requirements. Modular in design, BioGill Tower systems can be easily expanded with additional Towers, to accommodate changing treatment needs.

At the core of the BioGill Tower is patented nano-ceramic media, known as Gills. The unique design of the Gills provides the ideal habitat for microorganisms to grow, multiply and rapidly establish into a robust biomass. BioGill systems can be online and achieving treatment goals within days after start-up or system restart, making the units equally well suited to year-round or seasonal use.

BioGill media fosters a biomass that is remarkably tolerant of fluctuations in wastewater flow and Biochemical Oxygen Demand (BOD) and Chemical Oxygen Demand (COD)

loadings. This is a key benefit for small facilities with variations in wastewater producing activities over the course of the week or throughout the year. BioGill units can treat a wide range of influent BOD & COD concentrations and tolerate levels of Fat, Oil and Grease (FOG) that challenge or disrupt alternative biological treatment systems. As oxygen enters the Tower by natural convection currents through vents at the top and bottom of the bioreactor, there is no need for energy intensive blowers or aeration used in traditional technologies. This delivers significant savings in operating costs.

### CONFIGURATIONS

BioGill Tower Plus units can be arranged in single and multi-stage configurations to meet a wide range of flow, loading, and removal requirements. Systems are easy to expand through the addition of units or stages.

### BioGill Benefits



Meet compliance & discharge limits



Boost performance of existing plants



Resilient to shock loads & flow fluctuations



Save on surcharges



Reduce odor



Compact footprint modular & scalable

## Key Features

- “Plug & play” for quick installation
- Modular & scalable
- Rapid start-up & biomass build-up
- Simple to operate
- Minimal maintenance requirements
- Low energy & operating costs (no blowers or chemicals)
- Patented, non-clog HydroSwirl™ water dispersal system

## Key Benefits

Each BioGill Tower Plus includes:

- BioGill Tower bioreactor
- Recirculation pump
- Recirculation tank
- Tower stand
- Power isolator

## One Stage Configurations

BioGill Towers are designed to be modular and scalable with flexible configurations. Based on treatment requirements and hydraulic capacity, BioGill Tower Plus units can be configured in parallel (single stage) or series (double stage) connections. To simplify the design process, the units are supplied in predefined configurations as shown below.

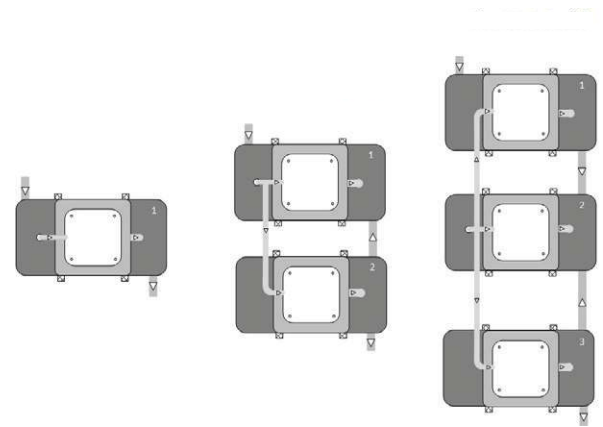

Top view schematic drawing of the Tower Plus - one stage configurations

## Two Stage Configurations

Also offered are several two stage configurations. By connecting the units in two stages, the hydraulic and treatment capacity of the units can be doubled.

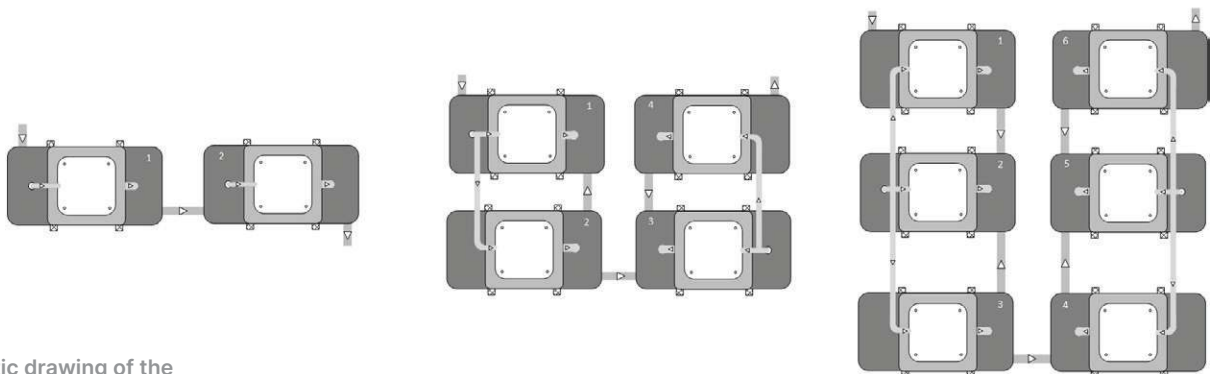

Top view schematic drawing of the Tower Plus - two stage configurations

## Performance Guide | BioGill Tower Plus

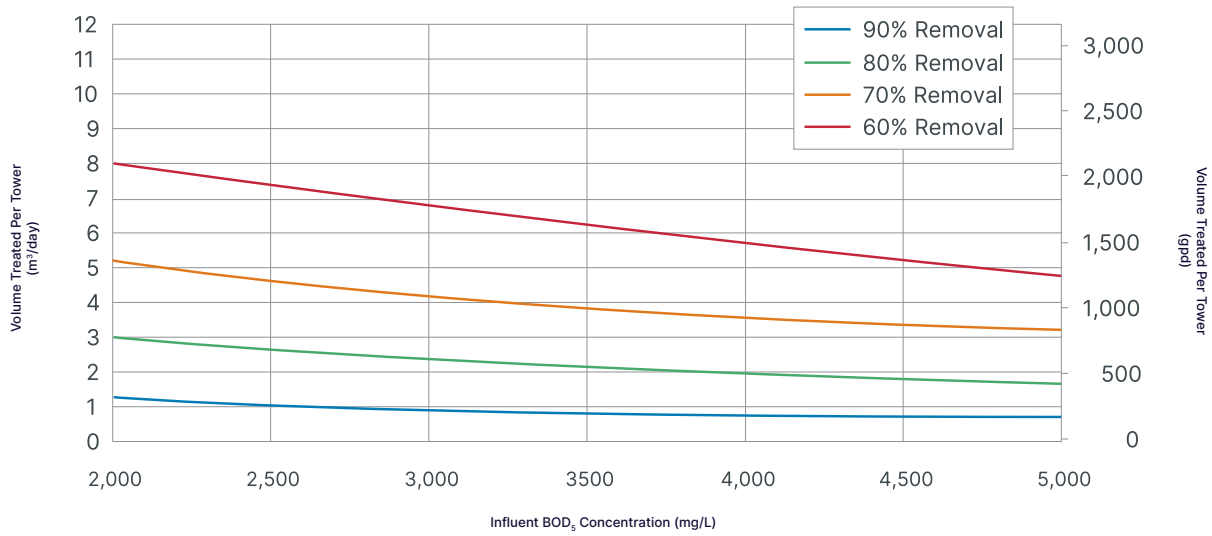

These performance graphs are to be used as a sizing guide only. Actual performance is determined by site specific factors and may vary. The above information is based on the following; a continuous flow system; brewery wastewater and water temperature at 86°F | 30°C. Removal rates and reductions are based on soluble BOD only. BioGill and its authorized representatives do not guarantee performance unless stated otherwise. For detailed system sizing or for information on projects outside these influent parameters, please contact your authorized BioGill representative.

## Technical Specifications

	Value (Imperial)	Value (Metric)	
OPERATING AND DESIGN INFORMATION*	Temperature range (wastewater)	65-100°F	18-37°C
	pH Range	6.5-8.5	
	Optimum C:N:P Ratio	100:10:1 to 100:5:0.5	
	Required Pre-treatment**	Influent TSS <300 mg/L   Maximum FOG <100 mg/L	
	Recirculation flow rate per Unit	18-44 gpm	4-10m³/hr
NOMINAL DIMENSIONS AND WEIGHTS	Gill Surface Area	2476ft²	230m²
	Overall length	7'8"	2337mm
	Overall width	4'10"	1480mm
	Overall height	10'6"	3200mm
	Overall footprint	37.24ft²	3.46m²
	Minimum height clearance	2'1"	600mm
	Recirculation Tank Capacity	500gals	1900L
	Tower Dry Weight	529 lbs	240 kg
	Tower stand weight	220 lbs	100 kg
RECIRCULATION PUMP SPECIFICATIONS	Recirculation tank weight	186 lbs	85 kg
	Max. wet weight***	7035 lbs	3190 kg
	Pump type	Submersible, vortex impeller	
	Motor output (Single unit   Two parallel units   Three parallel units)	1/3 HP   1/2 HP   1HP	0.25kW   0.4kW   0.75kW
	Motor phase	Single	
	Max head	21'4"   31'6"   41'	6.5m   9.6m   12.5m
TANK CONNECTIONS	Pump dry weight	17 lbs   17 lbs   21 lbs	7.7 kg   7.8 kg   9.5 kg
	Inlet connection	2" NPT female threaded fitting	DN50 BSPT Female threaded fitting
	Outlet connection	2" NPT female threaded fitting	DN50 BSPT Female threaded fitting
	Inter-unit connection	4" NPT female threaded fitting	DN100 BSPT Female threaded fitting
	Drain connection	2" NPT female threaded fitting	DN50 BSPT Female threaded fitting

\*Consult your authorized BioGill representative for information about specific applications. \*\*General recommendation - can vary depending on influent composition. \*\*\*Does not include recirculation pump.

## How BioGill Works

Biological wastewater treatment relies on microorganisms to consume organics in the wastewater. Like all living things, microorganisms need the right habitat to flourish. BioGill above ground bioreactors use patented Nano-ceramic media, known as Gills, to provide the ultimate air and liquid interface for the microorganisms to grow, multiply and thrive. Arranged in suspended vertical loops, each Gill is folded over a support, creating two distinct sides: one in contact with the water and the other in contact with the air.

By providing the perfect habitat, the microbes perform at their best, protected in the biofilm and effectively removing pollutants from the wastewater. BioGill solves many of the shortfalls of other technologies by delivering effective treatment of high organic waste streams, Fat, Oil and Grease (FOG), as well as reducing odor.

**Step 1** Wastewater is pumped to the top of the BioGill bioreactor.

**Step 2** The wastewater is then dispersed over the looped Gills and gravity fed down through the unit.

**Step 3** Biomass self-optimizes, growing the most suitable microbes to feed on a given wastewater. The result is a robust biomass that is more resilient to shock loads, FOG and high organic wastewaters.

**Step 4** Natural air convection, resulting from the heat generated by the biomass, creates a continuous supply of oxygen.

**Step 5** Treated wastewater exits the BioGill system with reduced levels of BOD, COD and FOG.

Fig 1. Gill structure

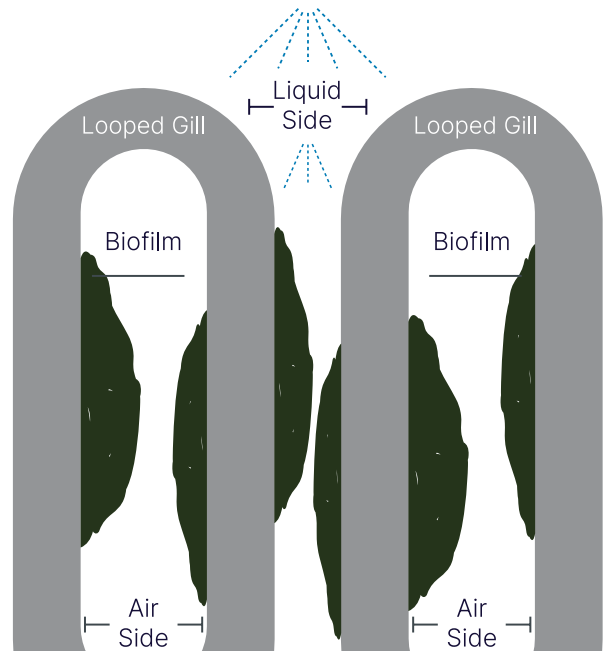

## For Further Information Please Contact

### Americas

E: [infoamericas@biogill.com](mailto:infoamericas@biogill.com)

### APAC

E: [infoasia@biogill.com](mailto:infoasia@biogill.com)

### China

E: [infochina@biogill.com](mailto:infochina@biogill.com)

Case studies and technical reports are available at [www.biogill.com](http://www.biogill.com)

